

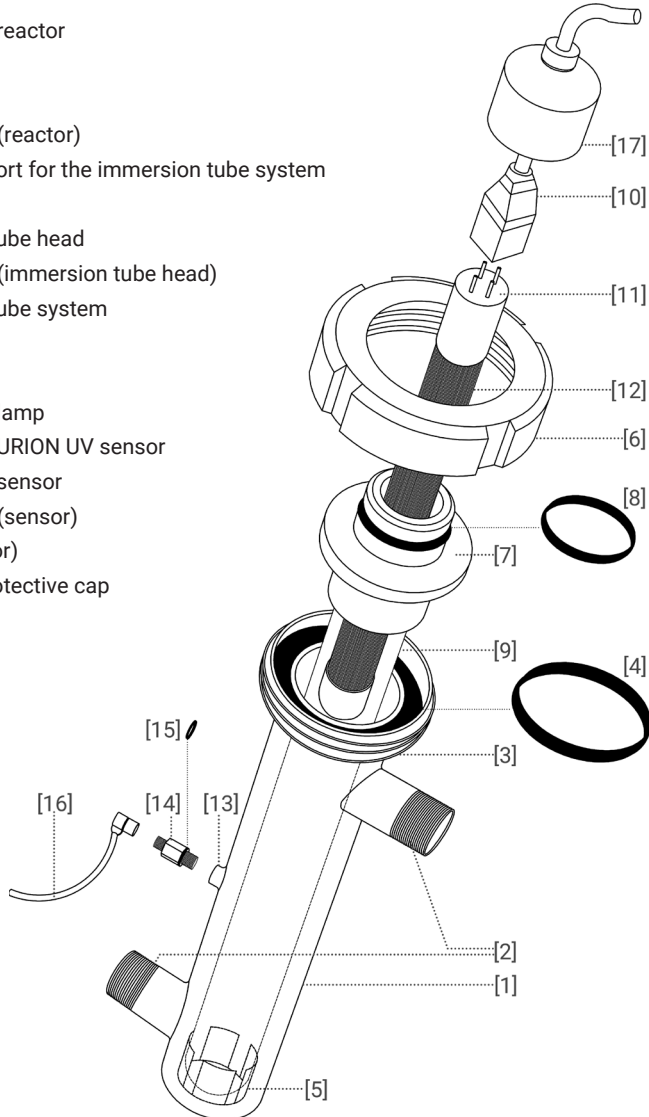

**PURION PLANTS (DIRECT CURRENT)
400 I 500 I 500 PRO I 1000 I 1000 PRO
ASSEMBLY AND OPERATION INSTRUCTION**



- [1] PURION UV reactor
- [2] flanges
- [3] screw neck
- [4] sealing ring (reactor)
- [5] clip as support for the immersion tube system
- [6] locknut
- [7] immersion tube head
- [8] sealing ring (immersion tube head)
- [9] immersion tube system
- [10] cable (lamp)
- [11] 4-pin plug
- [12] PURION UV lamp
- [13] socket for PURION UV sensor
- [14] PURION UV sensor
- [15] sealing ring (sensor)
- [16] cable (sensor)
- [17] PE-made protective cap



Safety Instructions

- This device is not to be operated by people with reduced physical, sensorial or mental capabilities or lack of experience and / or knowledge (including children).
- This device is a technical tool to be used in closed areas or receptacles.
- Protect your eyes and skin from UV light. In a very short period of time UV-C radiation generates severe sunburn and painful conjunctivitis in the eyes.
- The unintentional use of the device or a damaged housing may cause the spill of dangerous UV-C radiation.
- Devices showing evident damages must not be operated - please contact the manufacturer in case!
- The UV lamp is not to be operated outside the flow reactor.
- A long lasting interruption of the flow of water can lead to a heating of the surface of the reactor.
- Before opening the device, present operating and maintenance instructions should be read.
- **Caution: Areas which can only be opened by using a tool must to be considered as maintenance areas. Unauthorized opening may be dangerous for the operator !**



Assembly Instruction

General remarks

- The PURION UV-C-disinfection plant is always the last step in the chain of water treatment, since the distance to the sampling point should be as short as possible. Especially water filters provide perfect conditions for the grow of bacterias. The disinfected water would become infected again if it runs through the fresh-water circulation after the UV-C-plant. Pressure increasing devices should be installed before the UV-C-plants.
- Every PURION UV-C-lamp [12] has a decreasing UV-C power over operational time. The manufacturer guarentees, that the UV plant has 60% of the initial UV-C-power after 10.000 hours of operation. The design of the PURION UV plants is always done according to this 60% value of power and a transmission of 90 %T1cm. With more than 10.000 hours of operation the lamp will still work but will not provide sufficient UV-C power for an optimal result.
- Make sure that the reactor does not contain water during the frost period.

- **Installation should be carried out in accordance with the applicable regulations and by properly trained and qualified personnel. The contents of these instructions must be made available to the specialized personnel and duly implemented.**

step 1: preparation

- Please specify the installation location and the mounting position (vertical or horizontal). Make sure that there is enough space for changing the PURION UV lamp [12] or the immersion tube system [9]. If possible, choose a place of installation where the reactor [1] is not to be separated from the pipework for maintenance measures.
- Please also note that in order to ensure steady ventilation of the reactor the exhaust port (outlet of the water) should always be turned upwards. This ensures good ventilation and maximum turbulence in the water for optimum disinfection performance. Anyway, a flow from above is also possible and does not impair the disinfection effect.
- In principle, vertical and horizontal installation positions are possible. If possible, please choose a vertical installation position with screw neck [3] and locknut [6] in the upward direction.

step 2: installation of reactor and control box

- When integrating the reactor into the pipe system, please ensure that the thread transitions are sufficiently sealed. Please note that in order to have an easy sealing the flanges [2] have a slightly conical shape.
- The distribution box must be mounted on an even surface (e.g. wall or panel).
- For the installation of the switch box please use the wall tabs of the PURION assembly system. It is not necessary to open the switch box.
- For installation without the PURION assembly system, the prefabricated holes in the corners outside the sealing area of the cover are provided for mounting and have to be used accordingly. For this purpose the cover of the switch box has to be opened. In case of damage to the system without the PURION assembly set, the manufacturer's warranty is void.

step 3: start of operation

- Before releasing the immersion tube system [9] for water flow, please check whether it is sufficiently fixed by means of the locknut [6] (hand-tight).
- Before switching on, check if the PURION UV lamp [12] is connected to the 4-pin plug [11] of the lamp cable [10] and if it is inside the flow reactor.
- Switch on the system and check visually (via blue light at the PE-made protective cap [17] at the lamp cable or by control lights) the operation.

Operating Instruction PURION UV-plant

Scope of delivery:

- Flow reactor made of stainless steel with fitted immersion pipe system, waterside connection
R1" external thread (PURION 1000)
R1/2" external thread (PURION 400 and 500)
- 12 V DC or 24 V DC power supply for the UV lamp
- UV lamp 10 W (PURION 400 and 500), 17 W (PURION 1000)



Switch on of the UV-lamp:

- Connect the supply cable of the control box to the power source provided for the unit (supply voltage 12 V DC or 24 V DC).
- The function of the UV lamp after switching on must be checked via the transparent and UV-absorbing PE protective cap.

Connection type: Y

Direct connection to the existing 12 V or 24 V DC mains in accordance with the applicable directives and regulations.

Protection class: II



- **The cables should be laid without kinks. The bending radii must be observed.**
- The connection must be made according to the polarity indicated on the cables.

ATTENTION:

Only switch on the UV lamp when it is in the reactor vessel! If the supply voltage is <11 V (for 12 V DC systems) or <22 V (for 24 VDC systems) or if the lamp flickers, switch off the system and increase the charge level of the battery or check the input voltage (check using a meter).

Failure descriptions

- In case of insufficient disinfection performance, equipment is to be tested:

possible causes	measures to be taken
dirty quartz-made cladding tubes	cleaning of the immersion tube system with the PURION Service KIT
equipment overheating due to interrupted water flow	flow of water to be tested
lamp aging	replacement of lamp
air accumulation within the system	system to be ventilated

- In case of faulty power connection or faulty lamp cable, the supplier needs to be contacted.

Operating Time Counter (OTC)

** This chapter is only relevant if the OTC configuration has been chosen. **

- The system operates as a time counter. The counting starts if the system is switched on. With every switch on the so called "Startup Procedure" is carried out. To ensure operability the LED's flashes one after another: red, yellow and green 1 second each. Moreover the procedure can be interrupted to realize a reset of the counter.
- The monitoring system is designed as a traffic light. Two thresholds for UV intensity have been saved:
 - As long as the operating time is below 95% of the guaranteed life time the green LED is illuminated.
 - If the operating time exceeds 95% of the guaranteed life time the yellow LED is illuminated (pre alert).
 - If the operating time exceeds the guaranteed life time the red LED is illuminated (main alert).
- Adjustment of the system after replacement of the UV lamps:
 1. The unit is turned on – please wait until the UV lamp has started and the LED's have been illuminated
 2. press and hold the "Reset" button (approx. 2 seconds)
 3. release the „Reset“ button
 4. red LED is illuminated once – during illumination of the yellow LED the „Reset“ button is to be pressed and hold again (approx. 2 seconds)
 5. release the „Reset“ button
 6. red LED is illuminated once – during illumination of the yellow LED the „Reset“ button is to be pressed and hold again (approx. 2 seconds)
 7. release the „Reset“ button
 8. the "startup" procedure is carried out
 9. the system is adjusted and the green LED is illuminated.
- The Reset procedure is possible at all times since the OTC is not released with electronic ballast or the corresponding potential free contact.
- **After switch on at the main switch or via power supply line the operating time counter starts working.**
- It is urgently recommended to clean the immersion tube system with the PURION Service KIT at latest during replacement of the UV lamps.

Operating Power Detection (OPD)

** This chapter is only relevant if the OPD configuration has been chosen. **

- The Operating Power Detection (OPD) together with a suitable monitoring system is necessary for the surveillance of the service life of the uv-lamps based on measurement of the radiation power.
- This system directly detects the UVC intensity via sensor. The system starts measurement of the UVC-irradiance immediately after impressing of the operating voltage. With every switch on the so called "Startup Procedure" is carried out. To ensure operability the LED's flashes one after another red, yellow and green one 1s each. Moreover the procedure can be interrupted to adjust the system according to the current sensor value.
- The monitoring system is designed as a traffic light. Two thresholds for UV intensity have been saved:
 - As long as the UV intensity is more than 70% of the starting value the green LED is illuminated.
 - If the UV intensity goes below 70% of the starting value the yellow LED is illuminated.
 - If the UV intensity goes below 50% of the starting value the red LED is illuminated. To ensure disinfection the UV lamp has to be replaced.
- Adjustment of the system for initial operation and after replacement of the UV lamps:

The unit is turned on with the main power button or via power supply line. After lamps have been operated nearly six minutes the readjustment of the system can be carried out.

Before starting the adjustment a sufficient flow of water is to be ensured for at least two minutes.

 1. press and hold the "Reset" button (approx. 2 seconds)
 2. release the „Reset“ button
 3. red LED is illuminated once – during illumination of the yellow LED the „Reset“ button is to be pressed and hold again (approx. 2 seconds)
 4. release the „Reset“ button
 5. red LED is illuminated once – during illumination of the yellow LED the „Reset“ button is to be pressed and hold again (approx. 2 seconds)
 6. release the „Reset“ button
 7. the "startup" procedure is carried out
 8. the system is adjusted and the green LED is illuminated
- It is urgently recommended to clean the immersion tube system with the PURION Service KIT at latest during replacement of the UV lamps.

Maintenance - Cleaning of quartz-made cladding tubes

- Cleaning of the quartz-made protecting tube, as well as the radiator's removal/ replacement should be performed by duly trained personnel
- Any coatings originated by hardness components on the lamp's protective tube are to be removed. Cleaning should be performed with the PURION SERVICE KIT at least once a year.
- Procedure:
 - a) disconnect UV equipment / detach power plug from safety power outlet
 - b) empty the flow reactor
- Removal of PURION UV-lamp [12]:
 - use screwdriver for loosening polyethylene-made protective cap's [17] safety screw
 - loosen cable screwing
 - move the polyethylene-made protective cap back
 - withdraw UV lamp by its cable (**caution: may be hot**).
- Disassembling the quartz tube insert [9]:
 - loosen the grooved nut
 - disassemble the quartz tube insert
 - treat the quartz tube completely with a cleaning solution
 - allow for the cleaning agent to take effect, then rinse

Alternatively, the quartz tube may be wiped off with a rag soaked with a cleaning agent. (**Warning: in this case, wearing safety gloves becomes mandatory!**)

 - dirt on quartz tube's inner side to be removed with the PURION SERVICE KIT
- Reassembling the quartz tube's insert [9]:
 - caution: During reinstallation, attention must be paid to the quartz tube being introduced in a frontal position to the 4-side spring on the housing's bottom [5]
 - fasten the quartz tube's insert with the grooved nut
- Reassembling of the PURION UV-lamp [12]:
 - introduce UV radiator and cable through the stainless steel head into the quartz-made cladding tube until the bottom has been reached
 - push the transparent polyethylene-made protecting cap forward until the sealing of the immersion pipe's head has been reached
 - fasten the lamp's cable by means of cable screwing and implement traction relief
 - push transparent polyethylene-made protecting cap above the immersion tube's head as far as it will go
 - use a screwdriver for adjusting the safety screw of the PE-made protective cap [17]
- Restart the equipment

Maintenance – Replacement of the PURION UV lamp

- basically, the lamp should be replaced after a service life of about 10.000 hours. The replacement should be carried out by duly trained personnel.
- procedure:
Disconnect the UV system from the power supply at all poles using the main switch.
- Removal of PURION UV-lamp [12]:
 - use a screwdriver for loosening PE-made protective cap's [17] safety screw
 - loosen cable screwing
 - withdraw polyethylene-made protecting cap
 - pull UV lamp by its cable
 - detach the lamp from 4-contact plug (**caution: may be hot!**)
 - in doing so, touch UV radiator at the socket only (**glass-breaking danger!**)
- Cleaning : wipe off any existing fingerprints on the lamp's tube with an alcohol-soaked rag. Depositions on the quartz tube's inner side may be removed with the PURION SERVICE KIT entfernen.
- Reinstalling of the PURION UV-lamp [12]:
 - introduce UV radiator to the 4-contact cut-in unit's cable holder on lampside (remove fingerprints with an alcohol-soaked rag)
 - introduce UV radiator through the stainless steel head into the quartz-made cladding tube until the bottom has been reached
 - push transparent protecting cap up to the immersion tube's head sealing
 - fasten lamp's cable by means of cable screwing and implement traction relief
 - push transparent polyethylene-made protecting cap into the sealing of the immersion tube's head as far as it will go
 - adjust safety screw on the polyethylene-made protective cap [17] by using a screwdriver
- Restart the equipment

Hint: Independent of lamps' aging, the UV radiator's socket will turn into a brownish color under influence of UV light. This will not affect its correct operation.

Liability and warranty

- For warranty claims, we shall only be liable under the national legal warranty
- The general terms and conditions of PURION® GmbH are holding
- We explicitly point out that the warranty does not apply to damage caused by:
 - Operating failure in consequence of insufficient following this user information
 - Operating with spare parts such as Lamps and ballasts which are no PURION® original parts.
 - installation of incompliant accessories
 - incorrect operation / installation
 - removing, manipulating or non-insertion of protective devices
 - improper execution of maintenance
 - wear and non- exchanging of wear agents